



NEW PRODUCT

INFORMATION

AQ2000 AlemQube Self Bunded 2,000L Diesel Fuel Tanks with Self Mounting Options



AQ2000-2

October 2025



ALEM QUBE

Premium liquid storage is safe and convenient with the new Alemlube self-bunded range of AlemQube AQ Series tanks that include surface mounting options for pumps, reels and dispensing equipment.

The complete range includes tanks sized for up to 5,000L. Providing safe storage, compliant with Australian Standards, this new range is the ideal solution for your secure, onsite storage and dispensing of liquids including diesel fuel, oil, waste oil, kerosene, bio diesel and petrols.

This AQ2000 AlemQube tank has been designed and engineered by the Alemlube team to meet Australia's strict environmental and safety standards.

Holding 2,000L, this tank provides a durable, double-walled structure that eliminates the need for external bunding, reducing installation costs & saving valuable space.

SPECIFICATIONS, FEATURES & BENEFITS

- Self-bunded design is a double-walled construction that prevents leaks & eliminates the need for costly external bunding
- Tank dimensions are 2,268mm (W) x 1,270mm (H) x 1,086mm (D)
- Tank capacity of 2,000L SFL
- Tank weight of 876kg
- High quality mild steel construction with corrosion-resistant coating withstands harsh environmental conditions
- Compliant with Australian & International Standards for safe fuel storage AS1940-2017, UL142 & AS1692
- Custom decals are available to identify the fluid in use
- Flammable liquid kit available
- Designed for fast installation & easy relocation
- Use for on-site refuelling across agriculture and farming, construction and mining, transport & logistics
- Also suitable for oil
- Not suitable for Aviation Fuel or AdBlue®

Assembly and commissioning not included

For non-diesel applications please contact your closest Alemlube branch

AQ2000 DISPENSING OPTIONS

- Built-in diesel fuel pumping & dispensing options with a versatile range of electric pumps, flow meters, fuel monitoring & management systems able to be installed

PRODUCT CODE	DESCRIPTION	VOLTAGE	FLOW	METERED	AUTO NOZZLE	MANAGED	REMOTE LEVEL MONITORING
AQ2000	BARE TANK						
AQ2000-1	TANK WITH BASIC 12V PUMP	12V DC	50L/MIN	NO	YES	NO	NO
AQ2000-2	TANK WITH BASIC 12V PUMP WITH MECHANICAL FLOW METER	12V DC	50L/MIN	YES	YES	NO	NO
AQ2000-3	TANK WITH 240V NON MANAGED BOWSER (CUBE 70)	240V AC	70L/MIN	YES	YES	NO	NO
AQ2000-4	MANAGED 12V/24V PUMP - B-SMART SUPREME	12V/24V DC	50L/MIN	YES	YES	YES	NO
AQ2000-5	MANAGED 240V BOWSER - B-SMART	240V AC	70L/MIN	YES	YES	YES	NO
AQ2000-6	MANAGED 240V BOWSER - B-SMART WITH 4G LEVEL MONITORING	240V AC	70L/MIN	YES	YES	YES	YES



NEW PRODUCT

INFORMATION

AQ2000 AlemQube Self Bunded 2,000L Diesel Fuel Tanks with Self Mounting Options

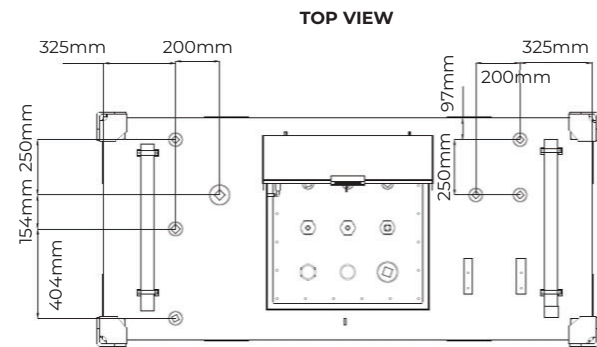
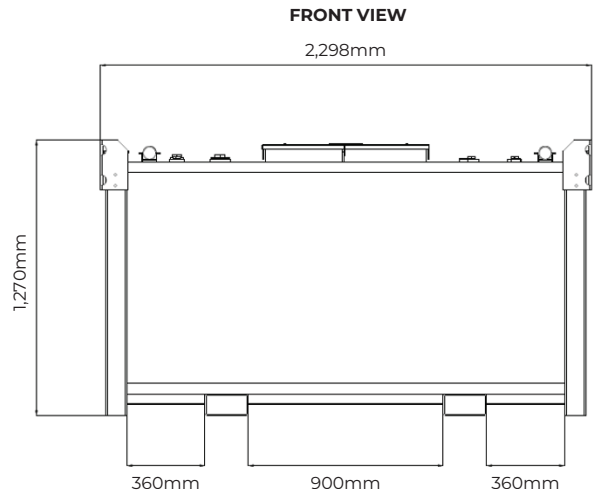
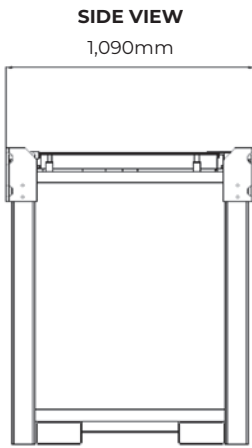

ALEMQUBE

October 2025

AlemQube has a large range of storage options available:

AQB Series Tanks

PRODUCT CODE	SAFE FILL LEVEL	DIMENSIONS	WEIGHT
AQB1000	1,000L	1,394mm (W) x 1,270mm (H) x 1,100mm (D)	640kg
AQB2000	2,000L	2,294mm (W) x 1,270mm (H) x 1,142mm (D)	950kg
AQB4000	4,000L	2,294mm (W) x 1,270mm (H) x 2,092mm (D)	1,350kg
AQB5000	5,000L	2,562mm (W) x 1,270mm (H) x 2,294mm (D)	1,582kg

AQ Series Tanks

PRODUCT CODE	SAFE FILL LEVEL	DIMENSIONS	WEIGHT
AQ1000	1,000L	1,374mm (W) x 1,270mm (H) x 1,086mm (D)	620kg
AQ2000	2,000L	2,268mm (W) x 1,270mm (H) x 1,086mm (D)	876kg
AQ3000	3,000L	2,294mm (W) x 1,270mm (H) x 1,592mm (D)	1,102kg
AQ4000	4,000L	2,268mm (W) x 1,270mm (H) x 2,058mm (D)	1,304kg
AQ5000	5,000L	2,460mm (W) x 1,270mm (H) x 2,268mm (D)	1,460kg

Alemlube can assist with dispensing options and maintenance programs.
For non-diesel applications please contact your closest Alemlube branch

www.alemlube.com.au

www.alemlube.co.nz

NSW/ACT (02) 9677 1555

QLD/PNG (07) 3491 2600

VIC/TAS (03) 8787 8288

WA (08) 9302 4199

SA/NT (08) 8241 7111

NZ (09) 447 1007